

Adjustable Hand Levers

Zinc Die Casting, Insert Steel,
with Internal or External Thread, with Washer

SPECIFICATION

Handle

Zinc die casting

Plastic coated

black, RAL 9005, textured finish **SW**

orange, RAL 2004, textured finish **OS**

red, RAL 3000, textured finish **RS**

silver, RAL 9006, textured finish **SR**

Version with bushing

Threaded insert and retaining screw
Steel, blackened

Version with threaded stud

Threaded stud and retaining screw
Steel

- Tensile strength class 5.8
- blackened

Washer

Steel

- case hardened
- blackened

INFORMATION

Adjustable hand levers GN 307 are ideal whenever parts have to be clamped in a confined space or in a particular lever position. On releasing the handle the serrations re-engage automatically.

When pulling the handle, the serration frees itself and can be re-located into any required position. Engagement is achieved by „releasing“ the lever.

The washer cannot be removed. One typical application is to use the hand lever for slots.

TECHNICAL INFORMATION

- Strength values of screws (see page A20)

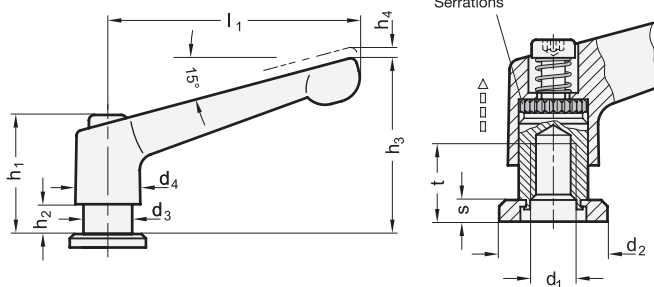

Application example

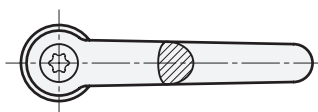
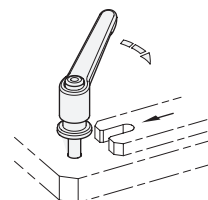

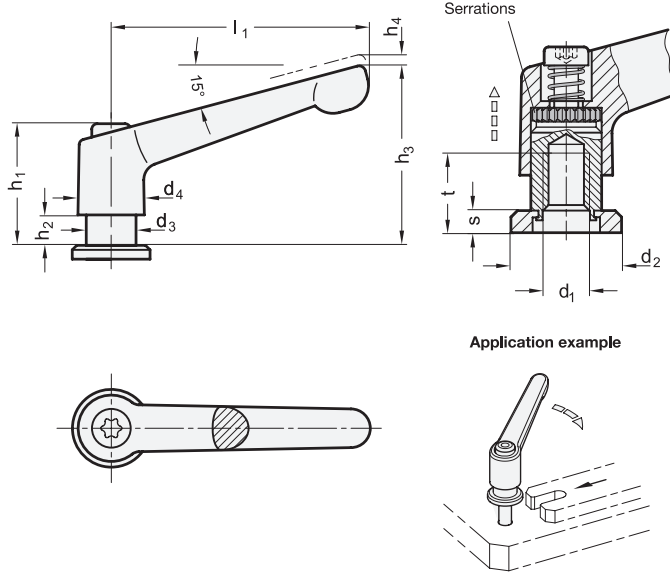



* Complete with colour index of the clamping lever body (SW, OS, RS or SR)

 SW	 OS	 RS	 SR
RAL9005	RAL2004	RAL3000	RAL9006

GN 307

Description	l1	d1	d2	d3	d4	h1	h2	h3	h4	s	t min.	
GN 307-30-M5-*	30	M5	13	10	13	24.5	4	31	3.5	2.5	10	27
GN 307-45-M6-*	45	M6	15	10	13	24.5	4	34	3.5	3	10	36
GN 307-63-M8-*	63	M8	20	13.5	17.5	31	6.5	45	4	3.5	13	80
GN 307-78-M10-*	78	M10	25	16	21	36	8	54	4	4	16	130

GN-307

Description	l1	d1	l2	d2	d3	d4	l3	h1	h2	h3	h4	s	
GN 307-30-M5-12-*	30	M5	12	13	10	13	0.4	24.5	4	31	3.5	2.5	29
GN 307-30-M5-16-*	30	M5	16	13	10	13	0.4	24.5	4	31	3.5	2.5	30
GN 307-30-M5-20-*	30	M5	20	13	10	13	0.4	24.5	4	31	3.5	2.5	31
GN 307-30-M5-25-*	30	M5	25	13	10	13	0.4	24.5	4	31	3.5	2.5	32
GN 307-30-M5-32-*	30	M5	32	13	10	13	0.4	24.5	4	31	3.5	2.5	33
GN 307-45-M6-16-*	45	M6	16	15	10	13	0.4	24.5	4	34	3.5	3	40
GN 307-45-M6-20-*	45	M6	20	15	10	13	0.4	24.5	4	34	3.5	3	41
GN 307-45-M6-25-*	45	M6	25	15	10	13	0.4	24.5	4	34	3.5	3	42
GN 307-45-M6-32-*	45	M6	32	15	10	13	0.4	24.5	4	34	3.5	3	43
GN 307-45-M6-40-*	45	M6	40	15	10	13	0.4	24.5	4	34	3.5	3	44
GN 307-63-M8-20-*	63	M8	20	20	13.5	17.5	0.4	31	6.5	45	4	3.5	91
GN 307-63-M8-25-*	63	M8	25	20	13.5	17.5	0.4	31	6.5	45	4	3.5	92
GN 307-63-M8-32-*	63	M8	32	20	13.5	17.5	0.4	31	6.5	45	4	3.5	95
GN 307-63-M8-40-*	63	M8	40	20	13.5	17.5	0.4	31	6.5	45	4	3.5	97
GN 307-63-M8-50-*	63	M8	50	20	13.5	17.5	0.4	31	6.5	45	4	3.5	100
GN 307-78-M10-20-*	78	M10	20	25	16	21	0.5	36	12	54	4	4	149
GN 307-78-M10-25-*	78	M10	25	25	16	21	0.5	36	12	54	4	4	151
GN 307-78-M10-32-*	78	M10	32	25	16	21	0.5	36	12	54	4	4	155
GN 307-78-M10-40-*	78	M10	40	25	16	21	0.5	36	12	54	4	4	159
GN 307-78-M10-50-*	78	M10	50	25	16	21	0.5	36	12	54	4	4	164

